



Rehab Demo Request Form

For client trials and evaluations

(Not applicable for retail showrooms)

As part of a field evaluation effort and in support of the therapy community, HealthCraft provides demonstration products to selected health care facilities for placement in ADL gyms and rehab rooms. To qualify for a potential donation, the applicant agrees to:

- Install and utilize the product for multiple client trials and evaluations only.
- Complete and return a Product Evaluation Form, typically 6 months after the donation. The questions on the Product Evaluation Form are related to product performance and functionality. The information provided helps us to make continued improvements to the product line.

Facility Contact Information

Facility Name: Website:

Shipping Address:

	Name (Title)	Telephone	e-mail
1st Contact:	<input type="text"/>	<input type="text"/>	<input type="text"/>
2nd Contact:	<input type="text"/>	<input type="text"/>	<input type="text"/>
Number of Therapists on Staff:	<input type="text"/>	Local DME Vendor:	<input type="text"/>

Product Selection Chart (One per Request)

Proposed Location of Product:

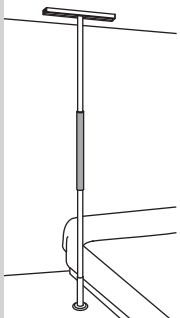
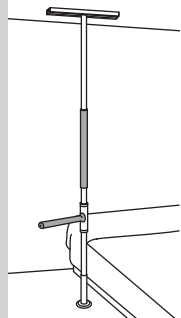
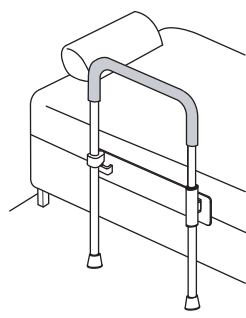
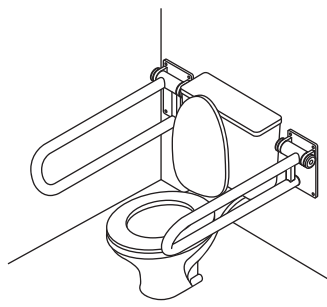
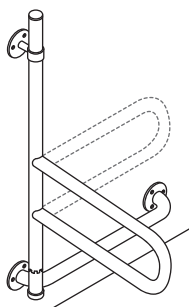
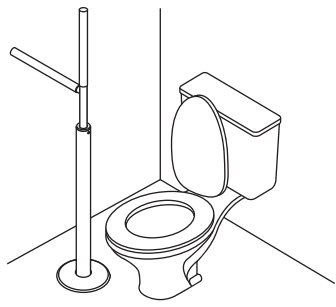
<p>Floor to Ceiling Height (inches)</p> <p>NOTE: If requesting a SuperPole product, measure the floor to structural ceiling height at installation location.</p> <p>For suspended ceilings, a ceiling tile can be removed to allow the SuperPole to reach structural ceiling up to 10 ft.</p>	<p>SuperPole™</p>  <input type="checkbox"/>	<p>SuperPole™ w/ SuperBar™</p>  <input type="checkbox"/>	<p>Smart-Rail™</p>  <input type="checkbox"/>
	<p>P.T.Rail™</p>  <input type="checkbox"/>	<p>Dependa-Bar™</p>  <input type="checkbox"/>	<p>Advantage Rail™</p>  <input type="checkbox"/>

Agreement: Fill out Form and Fax Back to 613-822-1886

I, Name (Title) Date Signature

agree to abide by the terms set out above.